

TrailerMaster Drain Valve Installation

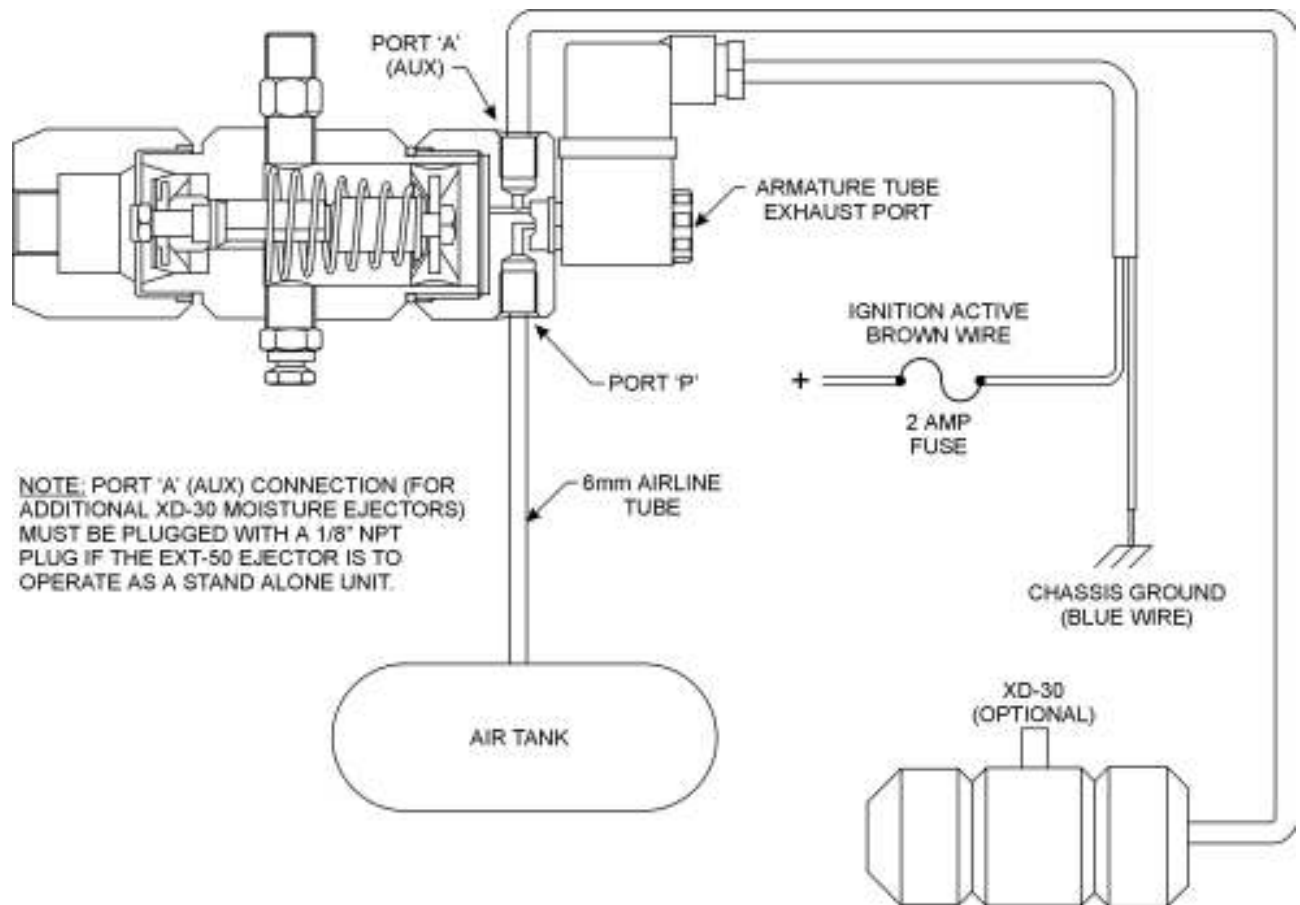

Note! The TrailMaster shown above is *de-energised* and in a *closed* position.

1. Connect the "Ignition Active Brown Wire" to the trailer "Brake Wiring".
2. Connect the "Chassis Brown Blue Wire" to the trailer chassis.
3. Connect a constant supply of air pressure to the TrailMaster's "P" Port.

OPERATION: -

The TrailMaster Drain Valve is powered by the trailer's braking system.

The TrailMaster will operate after 30 seconds of applying the trailer brakes.

General Pneumatics Pty Ltd
27 Hinkler Road, Mordialloc
Victoria, Australia 3195
www.generalpneumatics.com.au