



## XD-102 SERVICE KIT FOR EXT-50 DUMPMASTER DRAIN VALVE

- Drain all compressed air from air brake system.
- Remove all airlines connected to the drain valve.
- Firmly mount the ejector body where it is accessible for the service operation. Either leave it mounted or put it in a vice.
- Clean the outside of the Moisture Ejector and unscrew both end caps.
- Undo the nyloc XD-07 nut and remove bolt noting the location and order of all components.
- Clean and grease the Moisture Ejector bore using the tube of Teflon grease provided. Grease the new seals and the bore of the valve body.
- Fit the large black seal XD-12 onto the bolt followed by curved spring Retainer XD-09 *Spindle* XD-05 and *Spring* XD-11 as one assembly.
- Insert this assembly into the large bore of the Drain Valve body XD-01. It is important that the small end of the spring XD-11 is against the concave face of the curved brass spring retainer XD-09. The end or coil of the spring must not get caught between the curved spring retainer XD-09 and the spindle XD-05.
- Push on the head of the bolt XD-06 holding the assembly against the compressed spring. The thread of the bolt is now protruding out through to the exhaust side of the Drain Valve body X XD-01.
- Insert the spindle collet XD-08 followed by the greased seal XD-13 with the concave large diameter side towards the Drain Valve body XD-01.
- Insert the flat washer XD-10 and follow with the nyloc locknut XD-07.
- Tighten the nut and bolt to 30 inch pounds (2.4ft lbs) (3.5 Newton meter).
- Move the tightened seal assembly back and forth.
- Grease both end caps.
- Fit new O-Rings XD-14 & XD-15 to the valve Drain Valve body's threaded ends and reassemble end caps.

**PROPER OPERATION OF THIS XD-30 MOISTURE EJECTOR REQUIRES  
THE UNIT TO BE CLEANED, CHECKED FOR WEAR AND RE-GREASED  
AT LEAST ONCE EVERY YEAR.**

**CAUTION:** Eye protection must be worn when draining compressed air.

**DumpMaster® Drain Valves EXT-50 use the XD-102 Kit**

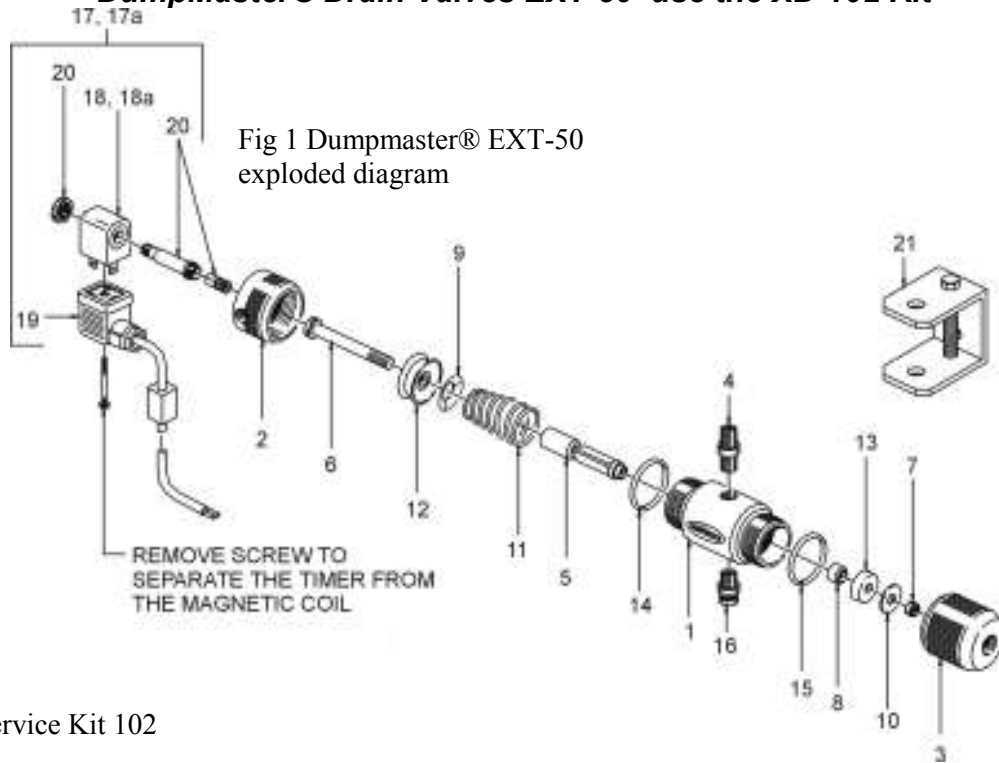
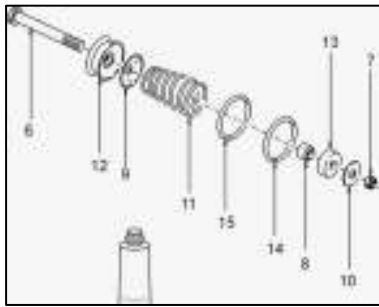

Fig 2 Service Kit 102



**DIMENSIONS: HEIGHT 49mm LENGTH 210mm**

Index No.	Part No.	Description	Index No.	Part No.	Description
1	XD-01	Ejector Body	9*	XD-09	<i>Spring Retainer</i>
2	XD-02	Actuating End Cap	10*	XD-10	<i>Flat Washer</i>
3	XD-03	Exhaust Cap	11*	XD-11	<i>Stainless Steel Spring</i>
4	XD-04	1/4" NPT Brass Nipple	12*	XD-12	<i>Actuator Piston Seal</i>
5	XD-05	Spindle	13*	XD-13	<i>Exhaust Seal</i>
6*	XD-06	<i>Bolt</i>	14*	XD-14	<i>O-Ring</i>
7*	XD-07	<i>Locknut</i>	15*	XD-15	<i>O-Ring</i>
8	XD-08	Spindle Collet	16	XD-16	Safety Drain Cock
		<i>Magnalube 4cc</i>	17	XD-17	Mounting Bracket

**NOTE! \* DENOTES COMPONENTS USED IN THE XD-102 KIT (9 Components)**



**GENERAL**  
PNEUMATICS

27 Hinkler Road, Mordialloc, Victoria 3195  
 Phone +61 3 9580 1811 Fax +61 3 9580 7542  
 E-mail sales@generalpneumatics.com.au  
 www.generalpneumatics.com.au